

不锈钢空心销轴链

Stainless steel hollow pin chains

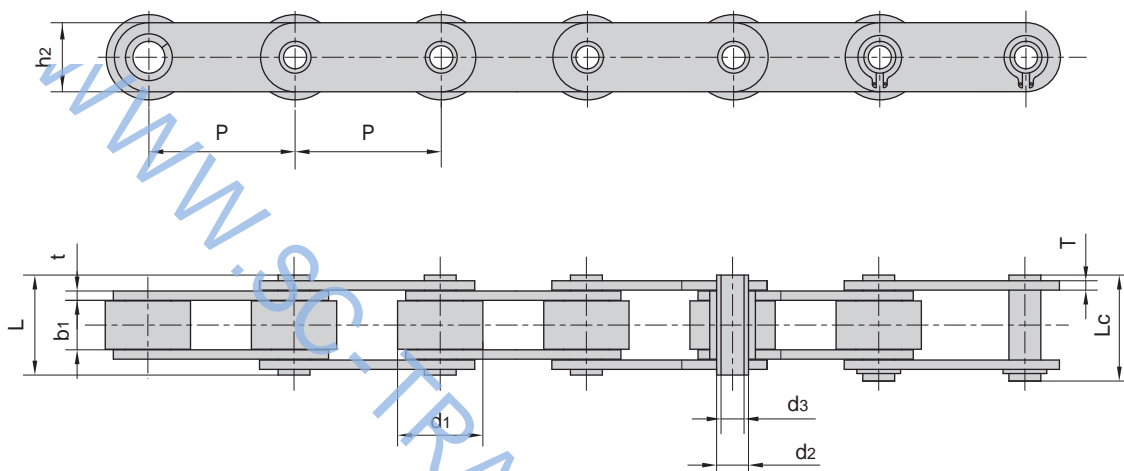

Chain No.	节距	滚子直径	内节内宽	销轴直径		销轴长度		内链板高度	链板厚度	破断载荷	每米长重
	Pitch	Roller diameter	Width between inner plates	Pin diameter		Pin length		Inner plate depth	Plate thickness	Breaking load	Weight per meter
	P	d1 max	b1 min	d2 max	d3 min	L max	Lc max	h2 max	T max	Q min	q
	mm	mm	mm	mm	mm	mm	mm	mm	mm	kN/lbf	kg/m
C2042HPSS	25.40	15.88	7.85	5.63	4.00	16.5	17.6	12.0	1.50	7.7/1750	0.79
C2052HPSS	31.75	19.05	9.53	7.22	5.12	20.5	21.8	15.0	2.03	14.3/3250	1.27
C2062HPSS	38.10	22.23	12.70	8.31	6.00	25.8	26.8	17.0	2.42	16.8/3818	1.74
C2082HPSS	50.80	28.58	15.75	11.40	8.05	32.4	33.8	24.0	3.25	35.0/7955	2.86
C2042H-HPSS	25.40	15.88	7.85	5.63	4.00	18.8	19.9	12.0	2.03	7.7/1750	0.96
C2052H-HPSS	31.75	19.05	9.53	7.22	5.12	22.1	23.4	15.0	2.42	14.3/3250	1.46
C2062H-HPSS	38.10	22.23	12.70	8.31	6.00	29.2	30.2	17.0	3.25	16.8/3818	2.02
C2082H-HPSS	50.80	28.58	15.75	11.40	8.05	36.2	37.6	24.0	4.00	35.0/7955	3.30

不锈钢短节距加长销轴输送链

Stainless steel short pitch conveyor chains with extended pins

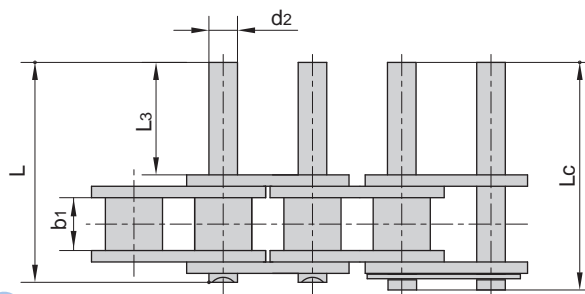
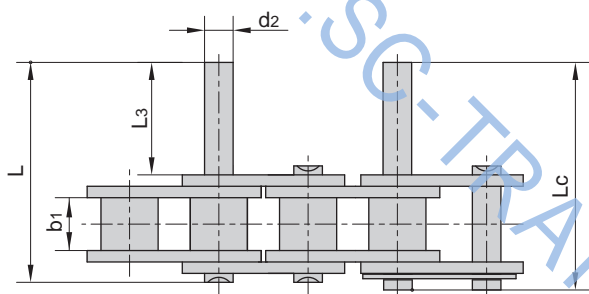
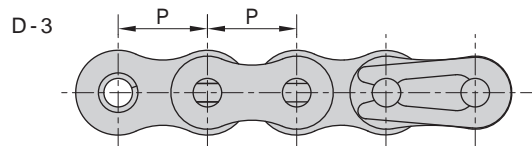
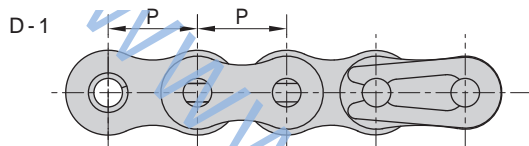

	P	b1	d2	L3	L	Lc
	mm	mm	mm	mm	mm	mm
06CSS	9.525	4.77	3.58	9.5	20.8	21.6
08ASS	12.700	7.85	3.96	9.5	25.1	26.2
10ASS	15.875	9.40	5.08	11.9	31.3	33.1
12ASS	19.050	12.57	5.94	14.3	38.6	40.6
16ASS	25.400	15.75	7.92	19.1	50.3	53.3
20ASS	31.750	18.90	9.53	23.8	61.8	66.1
24ASS	38.100	25.22	11.10	28.6	76.4	80.4
28ASS	44.450	25.22	12.70	33.3	84.8	89.4
32ASS	50.800	31.55	14.27	38.1	99.6	104.4
08BSS	12.700	7.75	4.45	9.5	25.1	26.6
10BSS	15.875	9.65	5.08	11.9	30.1	31.5
12BSS	19.050	11.68	5.72	14.3	35.4	37.1
16BSS	25.400	17.02	8.28	19.1	53.0	54.3
20BSS	31.750	19.56	10.19	41.0	79.9	83.6
24BSS	38.100	25.40	14.63	50.7	101.4	105.8
28BSS	44.450	30.99	15.90	61.9	124.0	128.4
32BSS	50.800	30.99	17.81	64.8	126.8	131.8

不锈钢双节距加长销轴输送链

Stainless steel double pitch conveyor chains with extended pins

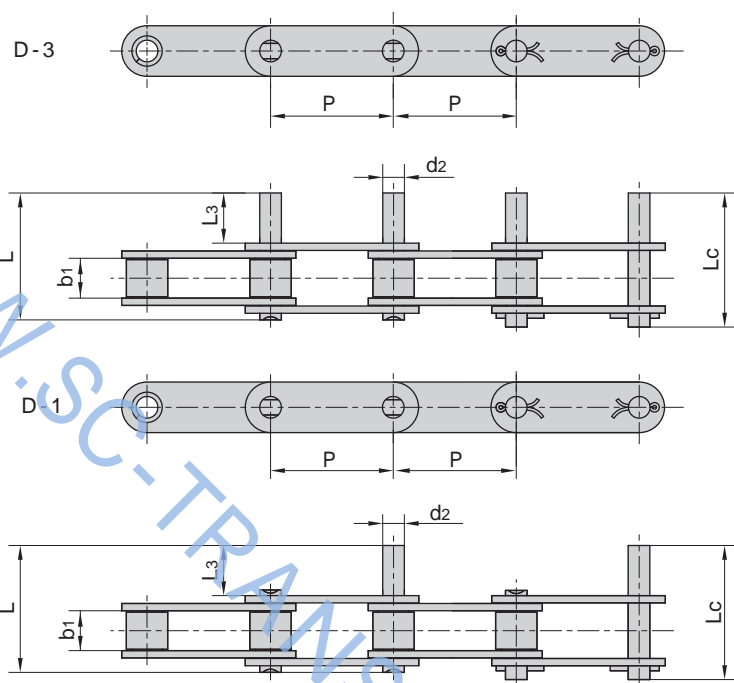

	P	b ₁	d ₂	L ₃	L	L _c
	mm	mm	mm	mm	mm	mm
C2040SS C2042SS	25.40	7.85	3.96	9.5	25.1	26.2
C2050SS C2052SS	31.75	9.40	5.08	11.9	31.3	33.1
C2060SS C2062SS	38.10	12.57	5.94	14.3	38.6	40.6
C2060HSS C2062HSS	38.10	12.57	5.94	14.3	42.0	43.8
C2080SS C2082SS	50.80	15.75	7.92	19.1	50.3	53.3
C2080HSS C2082HSS	50.80	15.75	7.92	19.1	53.5	55.0
C2100SS C2102SS	63.50	18.90	9.53	23.8	61.8	66.1
C2100HSS C2102HSS	63.50	18.90	9.53	23.8	65.0	68.3
C2120HSS C2122HSS	76.20	25.22	11.10	28.6	79.6	83.6
C2160HSS C2162HSS	101.60	31.75	14.27	38.1	103.0	107.8

不锈钢短节距输送链附件

Stainless steel short pitch conveyor chain attachments

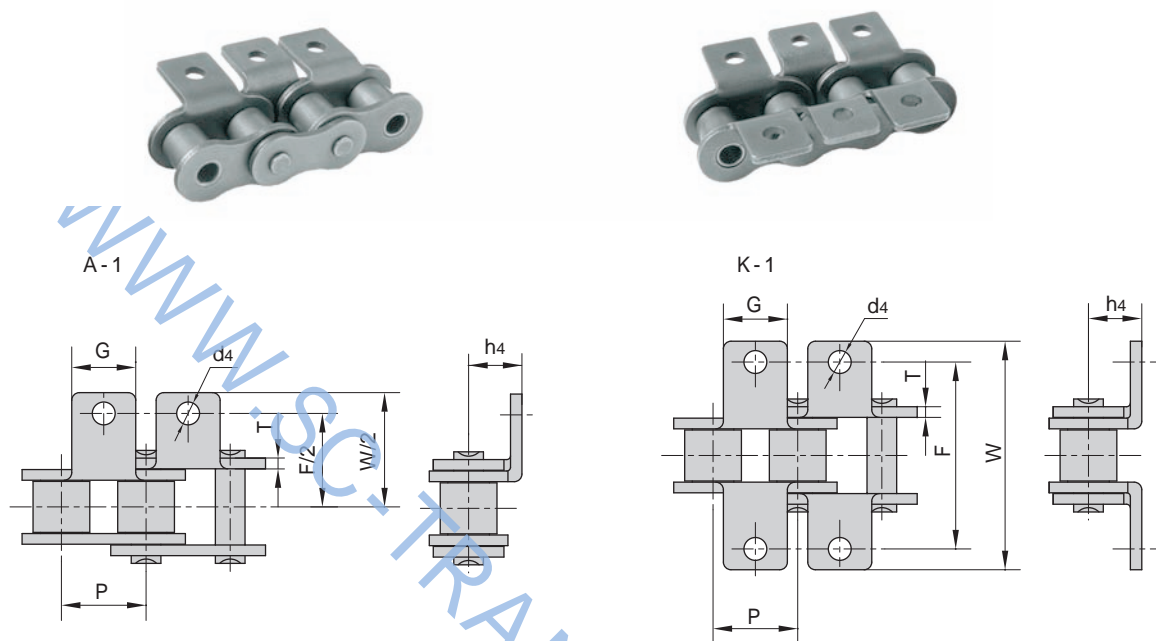

	P	G	F	W	T	h4	d4
	mm	mm	mm	mm	mm	mm	mm
08ASS	12.700	9.5	25.40	35.2	1.50	7.90	3.4
10ASS	15.875	12.7	31.75	46.2	2.03	10.30	5.5
12ASS	19.050	15.9	38.10	55.6	2.42	11.90	5.5
16ASS	25.400	19.1	50.80	64.8	3.25	15.90	6.8
20ASS	31.750	25.4	63.50	89.8	4.00	19.80	9.2
08BSS	12.700	9.5	25.40	36.4	1.60	8.90	4.5
10BSS	15.875	14.3	31.75	44.6	1.70	10.31	5.3
12BSS	19.050	16.0	38.10	52.4	1.85	13.46	6.4
16BSS	25.400	19.1	50.80	72.6	3.10	15.88	6.4
20BSS	31.750	35.0	63.50	100.5	3.50	19.80	9.0

不锈钢短节距输送链附件

Stainless steel short pitch conveyor chain attachments

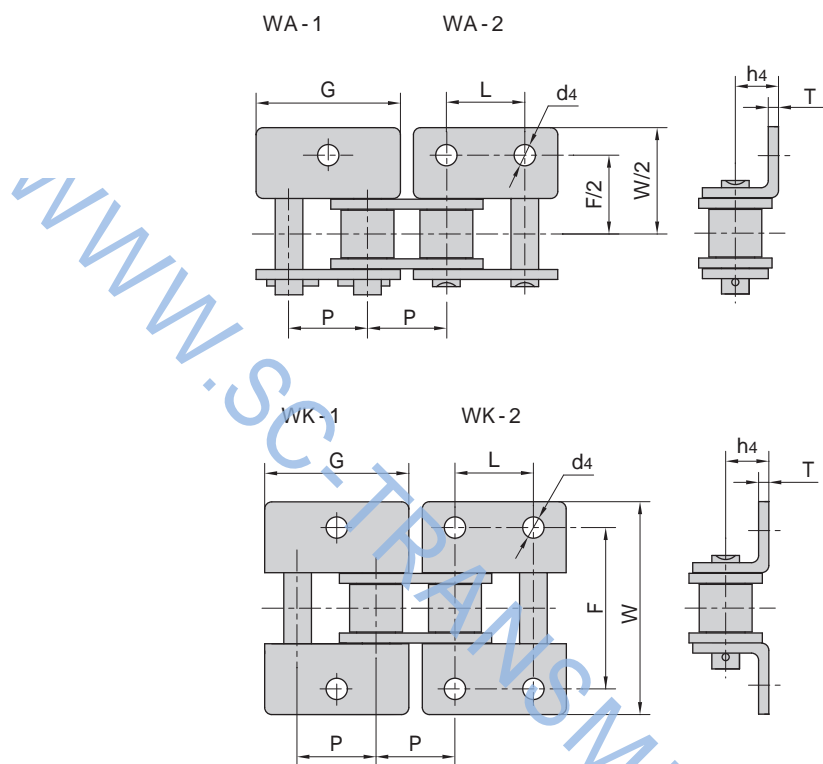

	P	G	L	F	W	T	h4	d4
	mm	mm	mm	mm	mm	mm	mm	mm
08ASS	12.700	23.00	12.700	25.4	35.60	1.50	7.90	3.4
10ASS	15.875	28.80	15.875	31.8	46.80	2.03	10.30	5.5
12ASS	19.050	34.65	19.050	38.1	56.40	2.42	11.90	5.5
16ASS	25.400	45.90	25.400	50.8	73.20	3.25	15.90	6.8
20ASS	31.750	57.65	31.750	63.5	89.80	4.00	19.80	9.2
08BSS	12.700	24.00	12.700	25.4	36.40	1.60	8.90	4.3
10BSS	15.875	29.58	15.875	31.8	44.60	1.70	10.31	5.3
12BSS	19.050	34.05	19.050	38.1	52.40	1.85	13.46	6.4
16BSS	25.400	46.40	25.400	50.8	72.60	3.10	15.88	6.4
20BSS	31.750	58.10	31.750	63.0	100.50	3.50	19.80	9.0

不锈钢滚子链

Stainless steel roller chains

不锈钢链条适合在易受食品、化学、药品等侵蚀场合使用，还可用于高低温场合。
 Stainless steel chains are suitable for corrosive conditions involving food, chemicals, pharmaceuticals, etc. and also suitable for high and low temperature conditions.

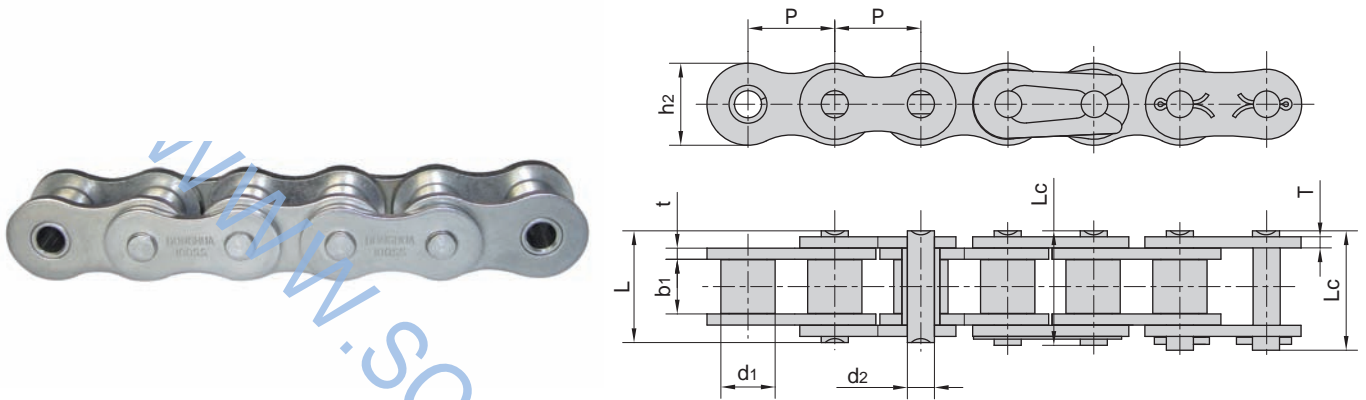

	节距 Pitch	滚子直径 Roller diameter	内节内宽 Width between inner plates	销轴直径 Pin diameter	销轴长度 Pin length		内链板高度 Inner plate depth	链板厚度 Plate thickness	破断载荷 Breaking load	每米长重 Weight per meter
	P	d1 max	b1 min	d2 max	L max	Lc max	h2 max	t/T max	Q	q
	mm	mm	mm	mm	mm	mm	mm	mm	kN/lbf	kg/m
*04CSS	6.350	3.30	3.18	2.31	7.90	8.40	6.00	0.80	2.5/568	0.15
*06CSS	9.525	5.08	4.77	3.58	12.40	13.17	9.00	1.30	5.5/1250	0.33
08ASS	12.700	7.95	7.85	3.96	16.60	17.80	12.00	1.50	9.6/2182	0.63
41SS	12.700	7.77	6.25	3.58	13.75	15.00	9.91	1.30	6.0/1360	0.46
10ASS	15.875	10.16	9.40	5.08	20.70	22.20	15.09	2.03	15.2/3455	1.03
12ASS	19.050	11.91	12.57	5.94	25.90	27.70	18.00	2.42	21.7/4932	1.51
16ASS	25.400	15.88	15.75	7.92	32.70	35.00	24.00	3.25	38.9/8841	2.62
20ASS	31.750	19.05	18.90	9.53	40.40	44.70	30.00	4.00	60.0/13636	3.94
24ASS	38.100	22.23	25.22	11.10	50.30	54.30	35.70	4.80	72.5/16477	5.72
28ASS	44.450	25.40	25.22	12.70	54.40	59.00	41.0	5.60	94.0/21363	7.70
04BSS	6.000	4.00	2.80	1.85	6.80	7.80	5.00	0.60	2.0/455	0.11
05BSS	8.000	5.00	3.00	2.31	8.20	8.90	7.10	0.80	3.5/795	0.20
#06BSS	9.525	6.35	5.72	3.28	13.15	14.10	8.20	1.30	6.2/1409	0.41
08BSS	12.700	8.51	7.75	4.45	16.70	18.20	11.80	1.60	12.0/2727	0.70
10BSS	15.875	10.16	9.65	5.08	19.50	20.90	14.70	1.70	14.5/3295	0.94
12BSS	19.050	12.07	11.68	5.72	22.50	24.20	16.00	1.85	18.5/4205	1.16
16BSS	25.400	15.88	17.02	8.28	36.10	37.40	21.00	4.15/3.1	40.0/9091	2.73
20BSS	31.750	19.05	19.56	10.19	41.30	45.00	26.40	4.5/3.5	59.0/13409	3.73
24BSS	38.100	25.40	25.40	14.63	53.40	57.80	33.20	6.0/4.8	104.0/25454	7.20
32BSS	50.800	29.21	30.99	17.81	66.00	71.00	42.00	7.0/6.0	150.0/34090	10.22

*套筒链：表中滚子直径d1为套筒直径
 *Bush chain: d1 in the table indicates the external diameter of the bush
 #直链板
 #Straight side plates

不锈钢空心销轴链

Stainless steel hollow pin chains

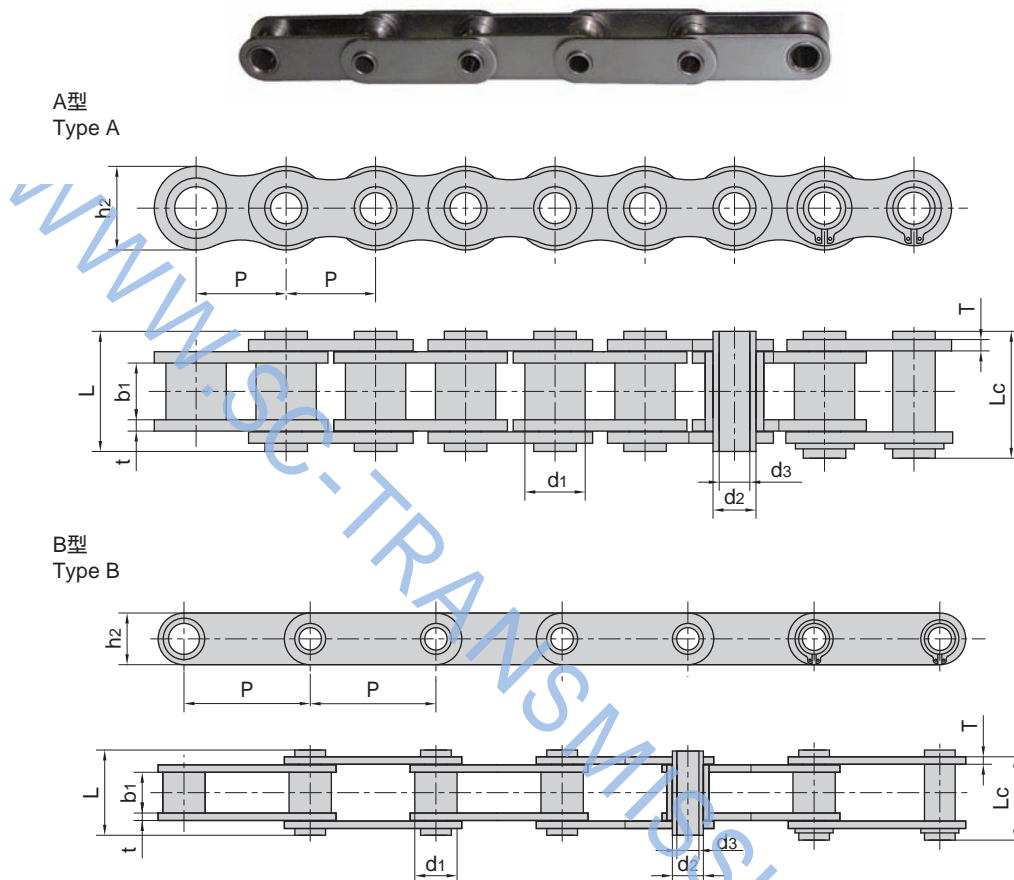

	节距 Pitch	套筒直径 Bush diameter	内节内宽 Width between inner plates	销轴直径 Pin diameter		销轴长度 Pin length		内链板高度 Inner plate depth	链板厚度 Plate thickness	破断载荷 Breaking load	每米长重 Weight per meter	型号 Type
	P	d1 max	b1 min	d2 max	d3 min	L max	Lc max	h2 max	t/T max	Q min	q	
	mm	mm	mm	mm	mm	mm	mm	mm	mm	kN/lbf	kg/m	
08BHPFSS	12.700	8.51	7.75	6.55	4.50	16.4	17.6	11.80	1.6/1.3	7.8/1773	0.57	A
40HPSS	12.700	7.95	7.85	5.63	4.00	16.5	17.6	12.00	1.50	7.7/1750	0.55	A
50HPSS	15.875	10.16	9.40	7.03	5.13	20.7	21.9	15.09	2.03	14.0/3182	0.92	A
60HPSS	19.050	11.91	12.70	8.31	6.00	25.8	26.8	18.00	2.42	16.8/3818	1.31	A
*12BHPSS	19.050	12.07	11.68	6.50	4.00	21.6	22.8	15.90	1.85	16.5/3750	1.10	A
80HPSS	25.400	15.88	15.75	11.40	8.05	32.5	33.8	24.00	3.25	35.0/7955	2.29	A
C2040HPSS	25.400	7.95	7.85	5.63	4.00	16.5	17.6	12.00	1.50	7.7/1750	0.47	B
C2050HPSS	31.750	10.16	9.40	7.22	5.12	20.5	21.8	15.00	2.03	14.3/3250	0.77	B
C2060HPSS	38.100	11.91	12.70	8.31	6.00	25.8	26.8	17.00	2.42	16.8/3818	1.03	B
C2080HPSS	50.800	15.88	15.75	11.40	8.05	32.5	33.8	24.00	3.25	35.0/7955	1.83	B
*HB50.8SS	50.800	30.00	10.50	11.40	8.20	27.4	28.6	26.00	3.10	35.0/7955	2.60	A

*滚子链：表中套筒直径d1为滚子直径

*Roller chain: d1 in the table indicate the external diameter of the roller

不锈钢空心销轴链

Stainless steel hollow pin chains

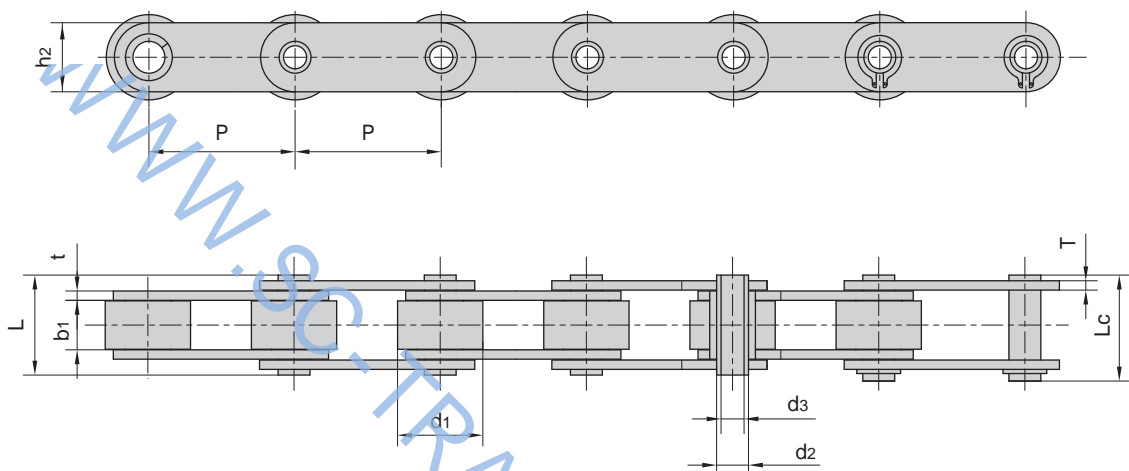

	节距 Pitch	滚子直径 Roller diameter	内节内宽 Width between inner plates	销轴直径 Pin diameter		销轴长度 Pin length		内链板高度 Inner plate depth	链板厚度 Plate thickness	破断载荷 Breaking load	每米长重 Weight per meter
	P	d1 max	b1 min	d2 max	d3 min	L max	Lc max	h2 max	T max	Q min	q
	mm	mm	mm	mm	mm	mm	mm	mm	mm	kN/lbf	kg/m
C2042HPSS	25.40	15.88	7.85	5.63	4.00	16.5	17.6	12.0	1.50	7.7/1750	0.79
C2052HPSS	31.75	19.05	9.53	7.22	5.12	20.5	21.8	15.0	2.03	14.3/3250	1.27
C2062HPSS	38.10	22.23	12.70	8.31	6.00	25.8	26.8	17.0	2.42	16.8/3818	1.74
C2082HPSS	50.80	28.58	15.75	11.40	8.05	32.4	33.8	24.0	3.25	35.0/7955	2.86
C2042H-HPSS	25.40	15.88	7.85	5.63	4.00	18.8	19.9	12.0	2.03	7.7/1750	0.96
C2052H-HPSS	31.75	19.05	9.53	7.22	5.12	22.1	23.4	15.0	2.42	14.3/3250	1.46
C2062H-HPSS	38.10	22.23	12.70	8.31	6.00	29.2	30.2	17.0	3.25	16.8/3818	2.02
C2082H-HPSS	50.80	28.58	15.75	11.40	8.05	36.2	37.6	24.0	4.00	35.0/7955	3.30

不锈钢双节距输送链

Stainless steel double pitch conveyor chains

小滚子型
Small roller type

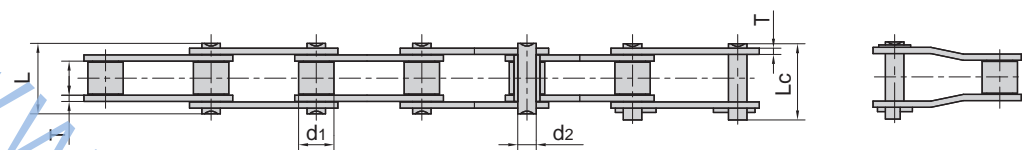
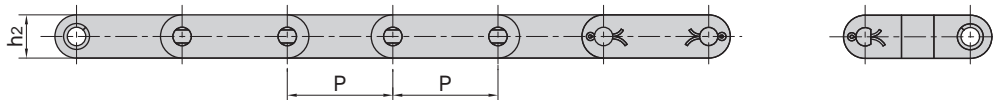

大滚子型
Large roller type

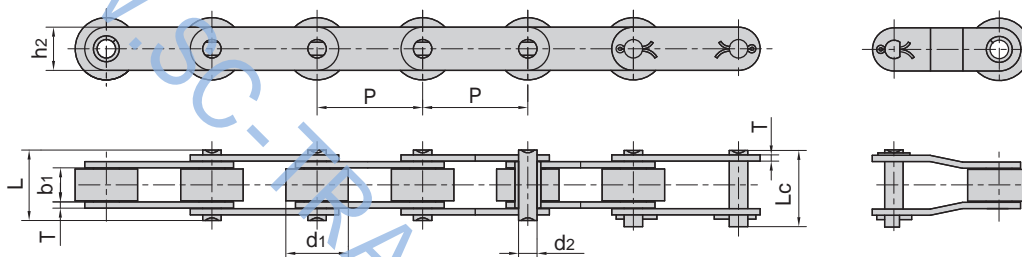

节距 Pitch	滚子直径 Roller diameter	内节内宽 Width between inner plates	销轴直径 Pin diameter	销轴长度 Pin length	内链板高度 Inner plate depth	链板厚度 Plate thickness	破断载荷 Breaking load	每米长重 Weight per meter
-------------	-------------------------	------------------------------------	----------------------	--------------------	----------------------------	-------------------------	-----------------------	--------------------------

	P	d1 max	b1 min	d2 max	L max	Lc max	h2 max	T max	Q min	q
	mm	mm	mm	mm	mm	mm	mm	mm	kN/lbf	kg/m
C2040SS C2042SS	25.40	7.95 15.88	7.85	3.96	16.6	17.8	12.0	1.50	9.6/2182	0.51 0.85
C2040HSS	25.40	7.95	7.85	3.96	18.8	19.9	12.0	2.03	9.6/2182	0.66
C208BSS C208BLSS	25.40	8.51 15.88	7.75	4.45	16.7	18.2	11.8	1.60	12.0/2727	0.56 0.90
C2050SS C2052SS	31.75	10.16 19.05	9.40	5.08	20.7	22.2	15.0	2.03	15.2/3455	0.79 1.29
C2060SS C2062SS	38.10	11.91 22.23	12.57	5.94	25.9	27.7	18.0	2.42	21.7/4932	1.13 1.63
C2060HSS C2062HSS	38.10	11.91 22.23	12.57	5.94	29.2	31.6	18.0	3.25	21.7/4932	1.46 2.10
C2080SS C2082SS	50.80	15.88 28.58	15.75	7.92	32.7	36.5	24.0	3.25	38.9/8841	2.11 3.16
C2080HSS C2082HSS	50.80	15.88 28.58	15.75	7.92	36.2	39.4	24.0	4.00	38.9/8841	2.57 3.63
C2100SS C2102SS	63.50	19.05 39.67	18.90	9.53	40.4	44.7	30.0	4.00	60.0/13636	3.05 4.89
C2100HSS C2102HSS	63.50	19.05 39.67	18.90	9.53	43.6	46.9	30.0	4.80	60.0/13636	3.61 5.45

不锈钢双节距输送链附件

Stainless steel double pitch conveyor chain attachments

A-1

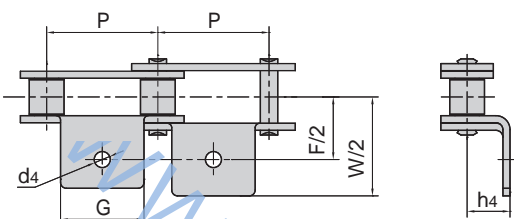

K-1

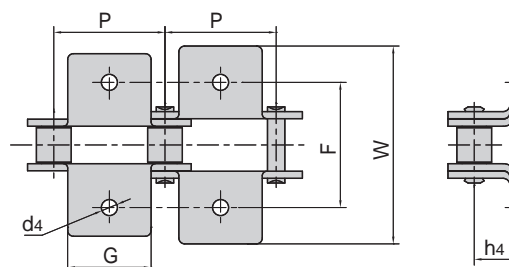

A-2

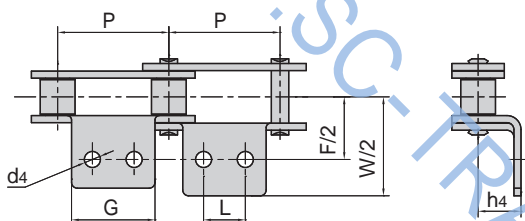

K-2

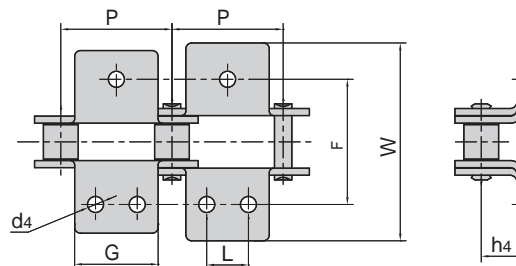

	P	G	L	F	W	h ₄	d ₄
--	---	---	---	---	---	----------------	----------------

mm mm mm mm mm mm mm

C2040SS C2042SS	25.40	19.1	9.5	25.4	39.6	9.1	3.4
C208BSS C208BLSS	25.40	23.2	12.7	25.4	39.6	9.1	4.5
C2050SS C2052SS	31.75	23.8	11.9	31.8	49.0	11.1	5.5
C2060SS C2062SS	38.10	28.6	14.3	42.9	67.8	14.7	5.5
C2060HSS C2062HSS	38.10	28.6	14.3	42.9	67.8	14.7	5.5
C2080SS C2082SS	50.80	38.1	19.1	55.6	87.8	19.1	6.8
C2080HSS C2082HSS	50.80	38.1	19.1	55.6	87.8	19.1	6.8
C2100SS C2102SS	63.50	47.6	23.8	66.6	107.5	23.4	9.2
C2100HSS C2102HSS	63.50	47.6	23.8	66.6	107.5	23.4	9.2

不锈钢短节距加长销轴输送链

Stainless steel short pitch conveyor chains with extended pins

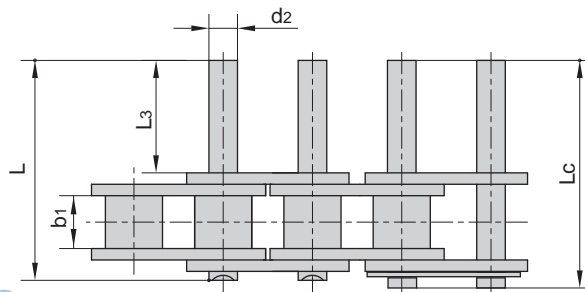
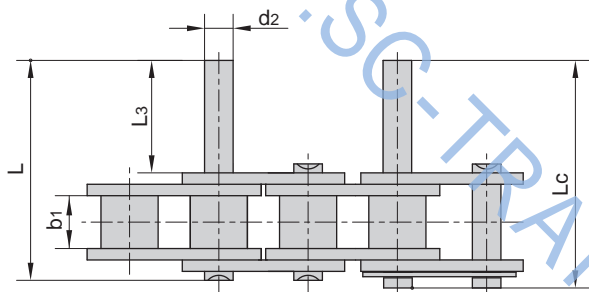
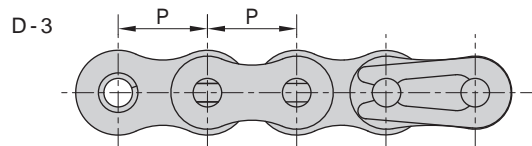
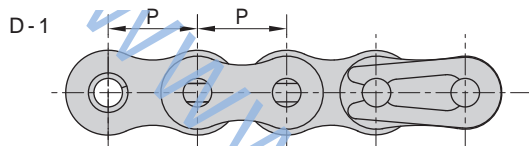

	P	b1	d2	L3	L	Lc
	mm	mm	mm	mm	mm	mm
06CSS	9.525	4.77	3.58	9.5	20.8	21.6
08ASS	12.700	7.85	3.96	9.5	25.1	26.2
10ASS	15.875	9.40	5.08	11.9	31.3	33.1
12ASS	19.050	12.57	5.94	14.3	38.6	40.6
16ASS	25.400	15.75	7.92	19.1	50.3	53.3
20ASS	31.750	18.90	9.53	23.8	61.8	66.1
24ASS	38.100	25.22	11.10	28.6	76.4	80.4
28ASS	44.450	25.22	12.70	33.3	84.8	89.4
32ASS	50.800	31.55	14.27	38.1	99.6	104.4
08BSS	12.700	7.75	4.45	9.5	25.1	26.6
10BSS	15.875	9.65	5.08	11.9	30.1	31.5
12BSS	19.050	11.68	5.72	14.3	35.4	37.1
16BSS	25.400	17.02	8.28	19.1	53.0	54.3
20BSS	31.750	19.56	10.19	41.0	79.9	83.6
24BSS	38.100	25.40	14.63	50.7	101.4	105.8
28BSS	44.450	30.99	15.90	61.9	124.0	128.4
32BSS	50.800	30.99	17.81	64.8	126.8	131.8

不锈钢双节距加长销轴输送链

Stainless steel double pitch conveyor chains with extended pins

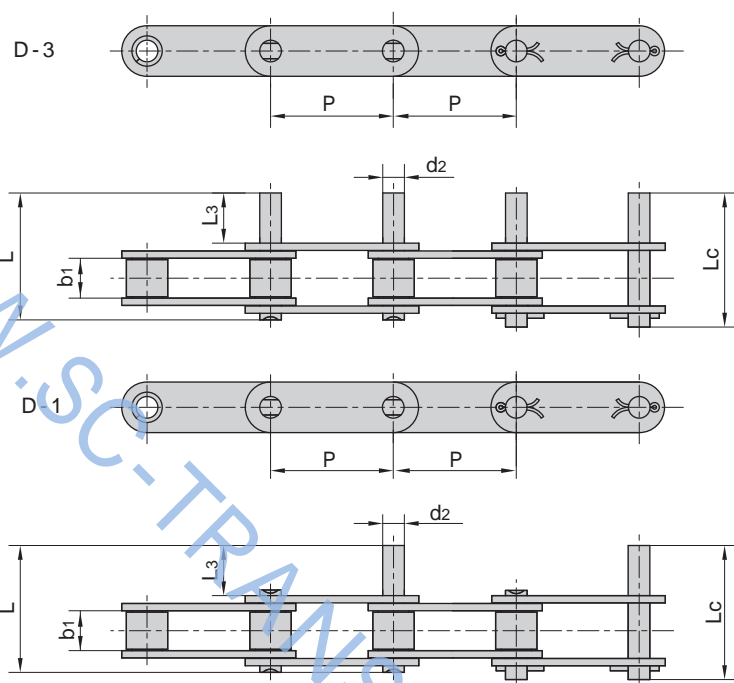

	P	b ₁	d ₂	L ₃	L	L _c
	mm	mm	mm	mm	mm	mm
C2040SS C2042SS	25.40	7.85	3.96	9.5	25.1	26.2
C2050SS C2052SS	31.75	9.40	5.08	11.9	31.3	33.1
C2060SS C2062SS	38.10	12.57	5.94	14.3	38.6	40.6
C2060HSS C2062HSS	38.10	12.57	5.94	14.3	42.0	43.8
C2080SS C2082SS	50.80	15.75	7.92	19.1	50.3	53.3
C2080HSS C2082HSS	50.80	15.75	7.92	19.1	53.5	55.0
C2100SS C2102SS	63.50	18.90	9.53	23.8	61.8	66.1
C2100HSS C2102HSS	63.50	18.90	9.53	23.8	65.0	68.3
C2120HSS C2122HSS	76.20	25.22	11.10	28.6	79.6	83.6
C2160HSS C2162HSS	101.60	31.75	14.27	38.1	103.0	107.8